

Signalétique Métro

LA FAMILLE SIGNALÉTIQUE

Document préliminaire

*Pour obtenir plus d'information sur les normes
signalétiques Métro en vigueur, contactez la STM.*



1 - Extérieur

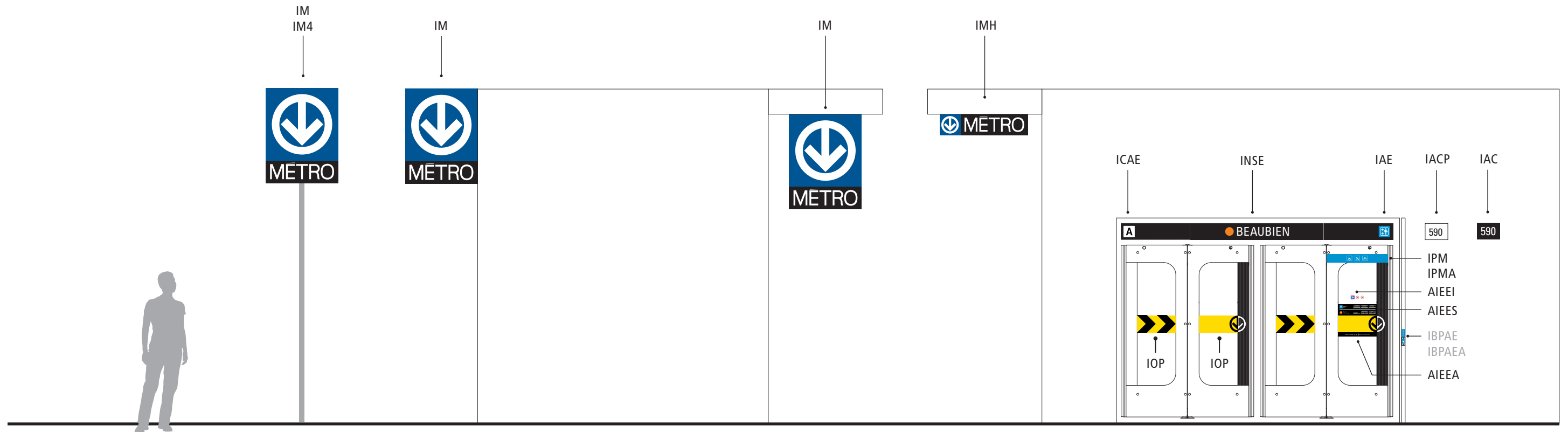

IM → Identification métro

IMH → Identification métro horizontal

IM4 → Identification métro 4 faces

IACP → Identification adresse civique prioritaire

IAC → Identification adresse civique

ICAE → Identification code d'accès extérieur

INSE → Identification nom de station extérieur

IAE → Identification ascenseur extérieur

IPM → Identification porte motorisée

IPMA → Identification porte motorisée - accessible

AIEEI → Affichage information édicule extérieur interdictions

AIEES → Affichage information édicule extérieur station

IBPAE → Identification bouton porte automatique extérieure

IBPAEA → Identification bouton porte automatique extérieure accessible

AIEEA → Affichage information édicule extérieur accessible

IOP → Identification ouverture de porte

2 - Édicule

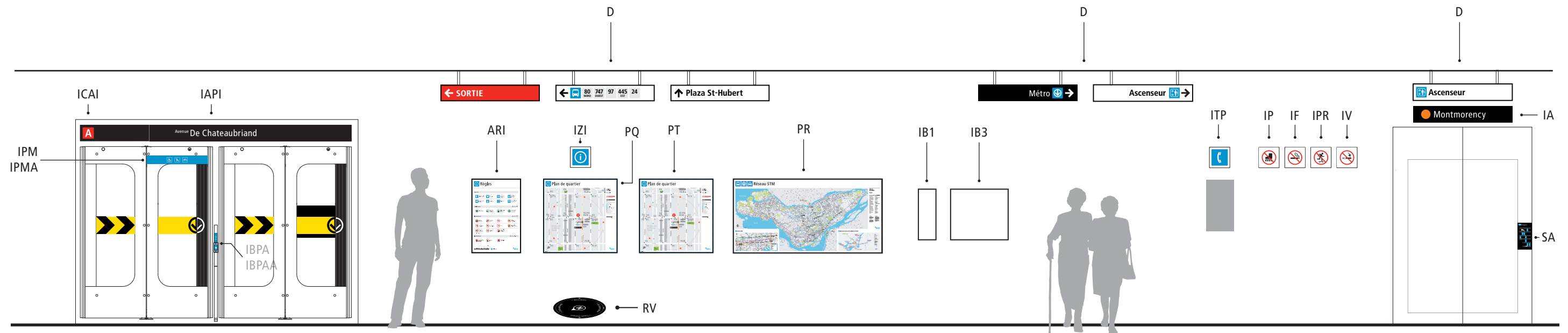

ICAI → Identification code d'accès intérieur

IAPI → Identification accès porte intérieure

IPM → Identification porte motorisée

IPMA → Identification porte motorisée - accessible

IBPA → Identification bouton porte automatique

IBPAA → Identification bouton porte automatique accessible

D → Directionnel

ARI → Affiche règlements

PQ → Plan de quartier

PT → Plan de terminus

PR → Plan réseau

IZI → Identification zone d'informations

RV → Rose des vents

IB1 → Infobus 1 place

IB3 → Infobus 3 place

ITP → Identification téléphone public

IP → Interdiction Patins

IF → Interdiction Fumer

IPR → Interdiction Planche à roulettes

IV → Interdiction vapoter

IA → Identification ascenseur

SA → Schéma ascenseur

3 - Transition

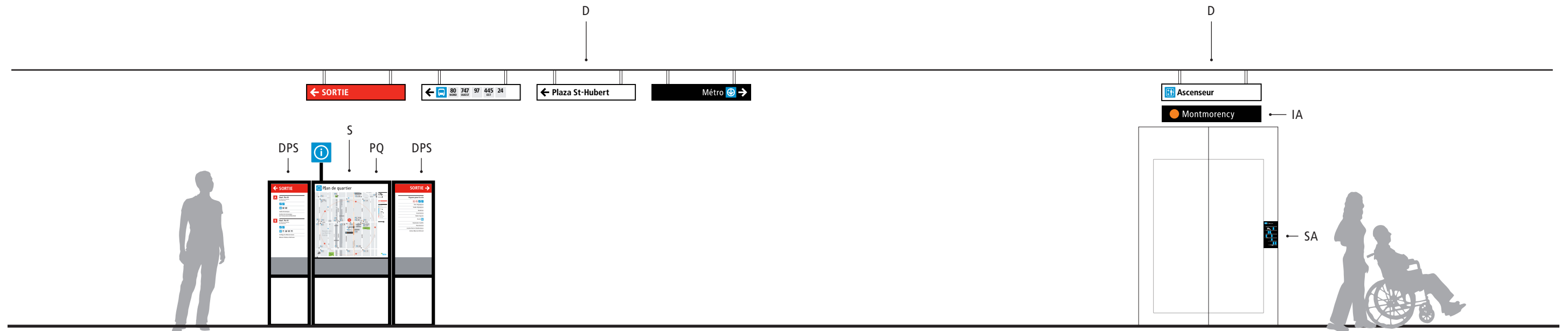

D → Directionnel

S → Stèle

PQ → Plan de quartier

DPS → Directionnel plan de sortie

IA → Identification ascenseur

SA → Schéma ascenseur

3 - Transition

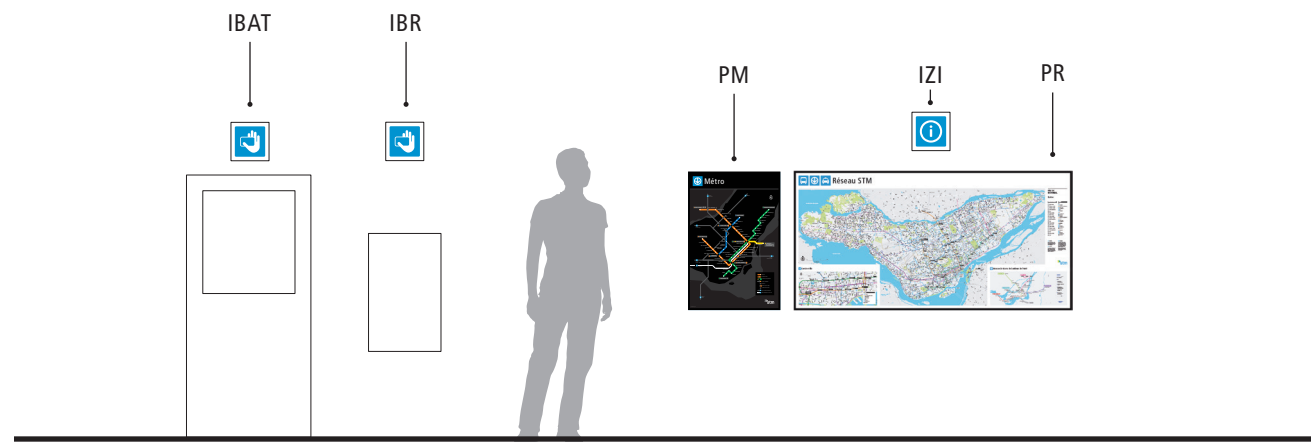

- IBAT → Identification borne achat de titre
- IBR → Identification borne recharge
- IZI → Identification zone d'informations
- PM → Plan métro
- PR → Plan réseau

4 - Loge et tourniquets

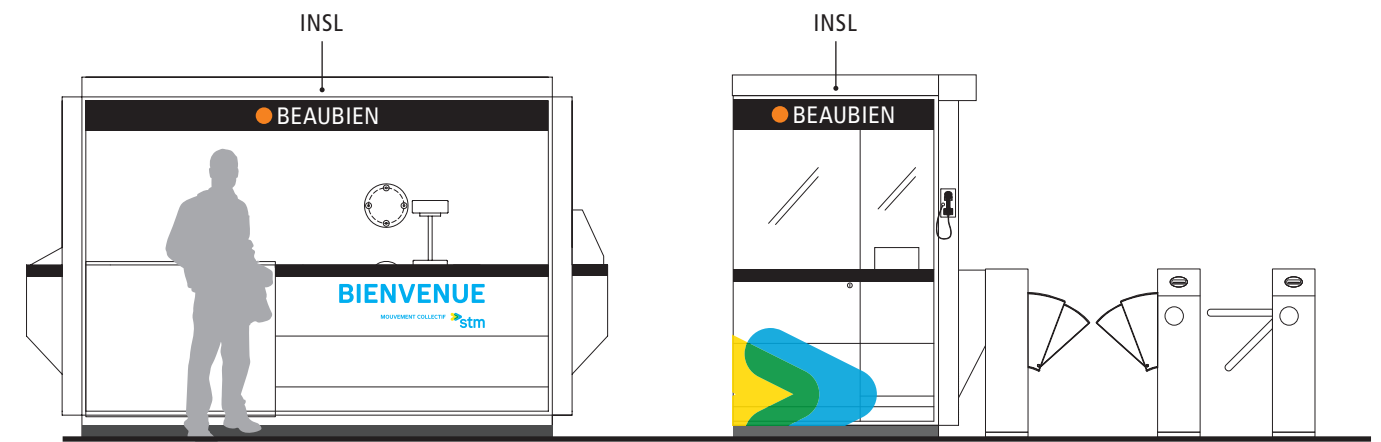

- INSL → Identification nom de station sur loge

4 - Loge et tourniquets

Entrée de station (Portillon à vantaux à la loge ou au centre)

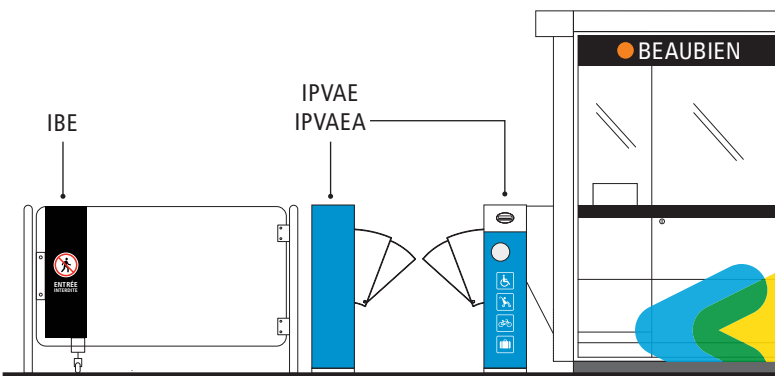

IBE → Interdiction barrière extérieure

IPVAE → Identification portillon à vantaux accessible extérieur

IPVAEA → Identification portillon à vantaux accessible extérieur - ascenseur

Sortie de station - cas #1 (Portillon à vantaux à la loge)

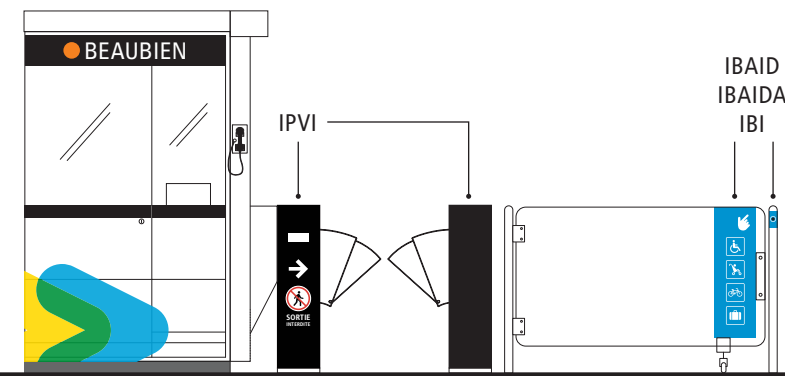

IPVI → Interdiction portillon à vantaux intérieur

IBAID → Identification barrière accessible intérieure droite

IBAIDA → Identification barrière accessible intérieure droite - ascenseur

IBI → Interdiction barrière intérieur

Sortie de station - cas #2 (Portillon à vantaux au centre)

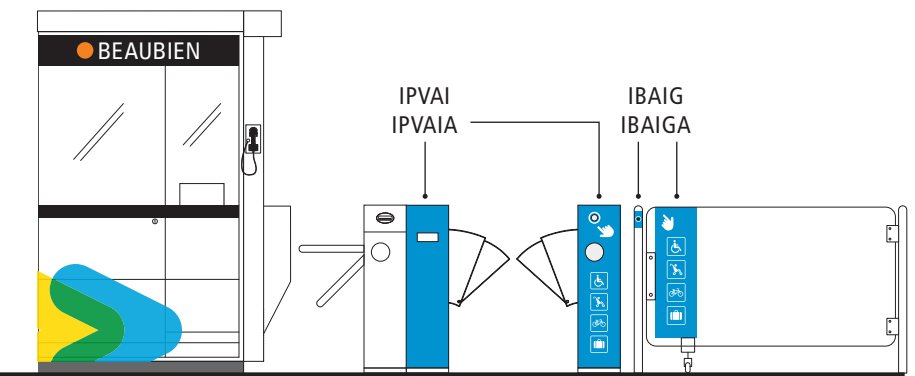

IPVAI → Indentification portillon à vantaux accessible intérieur

IPVAIA → Indentification portillon à vantaux accessible intérieur - ascenseur

IBAIG → Identification barrière accessible intérieure gauche

IBAIGA → Identification barrière accessible intérieure gauche - ascenseur

5 - Zone contrôlée

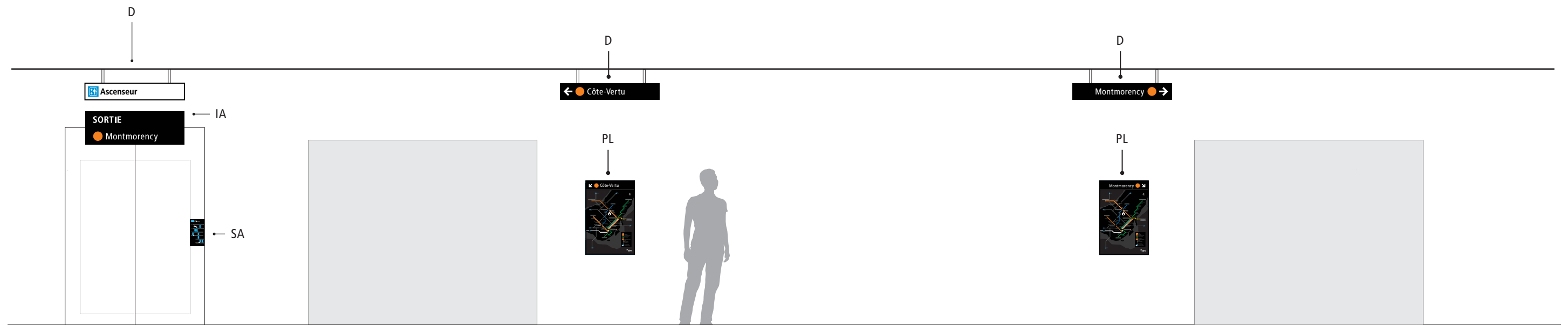

D → Directionnel

PL → Plan de ligne

IA → Identification ascenseur

SA → Schéma ascenseur

6 - Quai

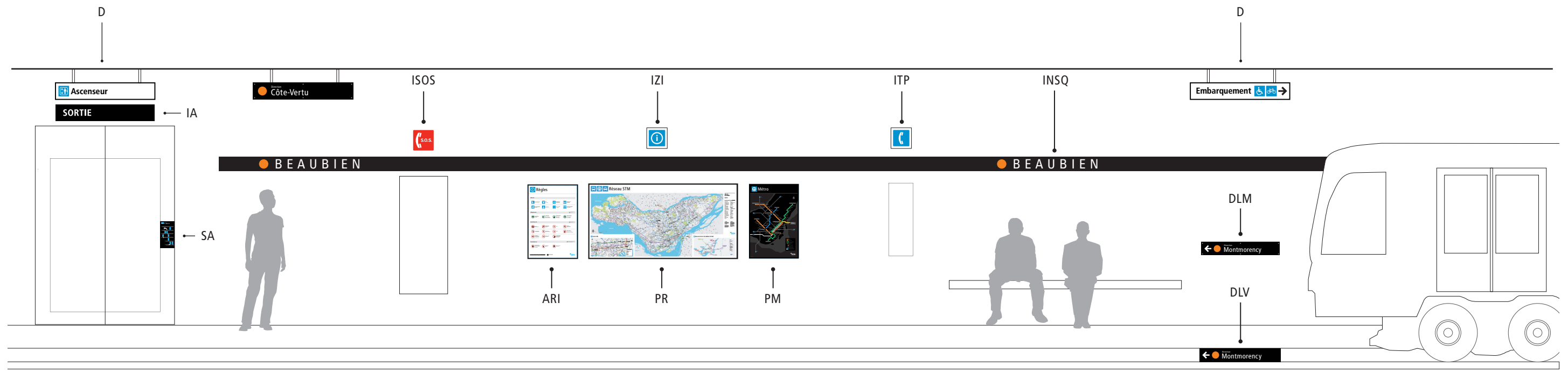

D → Directionnel

ISOS → Identification téléphone S.O.S.

IZI → Identification zone d'informations

ITP → Identification téléphone public

ARI → Affiche règlements intérieur

PR → Plan réseau

PM → Plan métro

IA → Identification ascenseur

INSQ → Identification nom de station sur quai

DLV → Directionel Ligne Voie

DLM → Directionel Ligne Mural

SA → Schéma ascenseur

ÉLÉMENTS DE CONCEPTION DE BASE

1 - Enseigne extérieur



PMS 286 C

C 100
M 60
Y 0
K 6

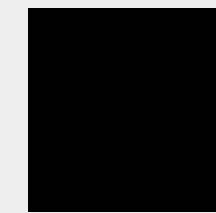

Noir Enrichi

C 40
M 40
Y 40
K 100

2 - Couleurs

Bleu STM



PMS Process Blue C

C 100
M 10
Y 0
K 10

Bleu Ens. de métro



PMS 286 C

C 100
M 60
Y 0
K 6

Noir Enrichi



Noir Enrichi

C 40
M 40
Y 40
K 100

Gris



Gris pâle

K 0 K 100

Couleurs de lignes de métro

Ligne Orange



PMS 158 C

C 0
M 60
Y 100
K 0

Ligne Verte



PMS 355 C

C 100
M 0
Y 100
K 0

Ligne Bleu



PMS 300 C

C 100
M 50
Y 0
K 0

Ligne Jaune



PMS 109 C

C 0
M 10
Y 100
K 0

Couleurs de signalisation

Rouge Urgence

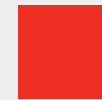

PMS 485 C

C 0
M 95
Y 100
K 0

Jaune avertissement



PMS 109 C

C 0
M 10
Y 100
K 0

Vert Obligation



PMS 348 C

C 96
M 2
Y 100
K 12

Bleu Assistance



PMS 2945 C

C 100
M 53
Y 2
K 16

Vinyle rétroéclairé

Ligne Orange



3M 3630-44
Orange

Ligne Verte



3M 3630-76
Holly green

Ligne Bleu



3M 3630-167
Bright blue

Ligne Jaune



3M 3630-25
Sunflower

Couleurs pour le rétroéclairé (PACOS)

Ligne Orange



PMS 158 C

C 0
M 36
Y 60
K 0

Ligne Verte



PMS 355 C

C 90
M 0
Y 90
K 0

Ligne Bleu



PMS 300 C

C 60
M 30
Y 0
K 0

Ligne Jaune



PMS 109 C

C 0
M 7
Y 100
K 0

Bleu STM



PMS P. Blue C

C 60
M 0
Y 0
K 0

Noir Enrichi

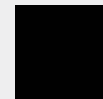

C 40
M 40
Y 40
K 100

Rouge Urgence

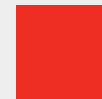

PMS 485 C

C 0
M 95
Y 100
K 0

Jaune avertissement



PMS 109 C

C 0
M 0
Y 90
K 0

Vert Obligation



PMS 348 C

C 67
M 1
Y 70
K 2

Bleu Assistance



PMS 2945 C

C XX
M XX
Y XX
K XX

Bleu Ens. Métro



PMS 286 C

C 60
M 36
Y 0
K 4

Gris pâle

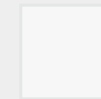

C 0
M 0
Y 0
K 3

3 - Police de caractère

Transit print regular a b c d e f A B C D E F 0 1 2 3 4 5

Transit print bold **a b c d e f A B C D E F 0 1 2 3 4 5**

Transit back negative **a b c d e f A B C D E F 0 1 2 3 4 5**

Transit back positive **a b c d e f A B C D E F 0 1 2 3 4 5**

Univers 57 condensed a b c d e f A B C D E F 0 1 2 3 4 5

4 - Pictogrammes TRANSPORT



Métro



Bus



Train de banlieue



Train



Taxi



Vélo



Arrêt de bus

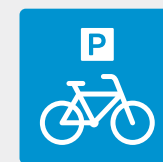

Stationnement vélo



Embarquement
(Bus)



Débarcadère
(Bus)



Gare d'autocars



Transport adapté



Débarcadère
(Voiture)



Embarquement
(Voiture)



Débarquer la nuit
(Femme)



Covoiturage
(Voiture)



Flèche
(Horizontal - vertical)



Flèche
(Diagonal)



10 mintes max.



747 - Bus Aéroport



Réseau de nuit



Réseau express



Navettes



SPS - Service
provisoire de surface



SPS ligne orange



SPS ligne verte



SPS ligne bleue



SPS Ligne jaune

5 - Pictogrammes SERVICES



Service à la clientèle
Espace client



Loge temporaire



Sûreté et contrôle



Centre photo

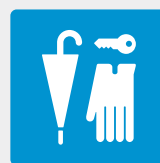

Objets trouvés



Renseignements



Zone d'information



Hopital



Stationnement



Téléphone



Toilettes

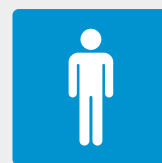

Toilettes hommes

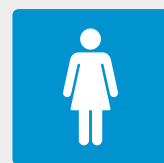

Toilettes femmes



Musée



Parc



Café



École



Bagage



Commerce

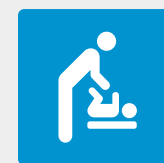

Table à langer



Commerce



Table à langer



Centre sportif



Bibliothèque



Achat de titres



Recharge OPUS



Titres de transport



Correspondance



Tarification



Carte OPUS
Enregistrer ou remplacer



Carte OPUS
Récupérer le solde



Carte OPUS
Obtenir informations



Carte OPUS
Carte avec photo



Carte OPUS
Obtenir formulaire

6 - Pictogrammes ACCESSIBILITÉ et ÉQUIPEMENT

ACCESSIBILITÉ



Fauteuil roulant



Poussette



Femme enceinte



Homme en canne



Blessé



Toilettes accessibles hommes



Toilettes accessibles femmes



Téléphone



Téléphone texte



Téléphone avec contrôle du volume



Assistance téléphonique



Aveugle



Instructions Bus / Azur

ÉQUIPEMENTS



Escalier mécanique



Escalier mécanique Monter



Escalier mécanique Descendre



Ascenseur



Escalier Fixe

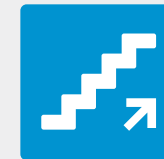

Escalier Fixe Monter

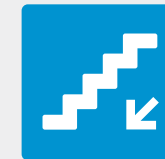

Escalier Fixe Descendre



Camera de surveillance



Bus climatisé



Réparation

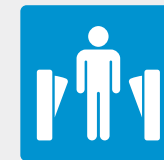

Portillon

7 - Pictogrammes ASSISTANCE et COMPORTEMENT

ASSISTANCE



Interphone AZUR



Interphone MR-63 et MR-73



Parler



Écouter



Descendre dans le tunnel



Suivre les instructions



Camera de surveillance

COMPORTEMENTS

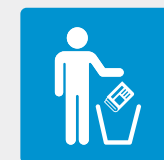

Recycler votre journal dans les bacs prévus.



Porter un chandail.



Céder votre siège aux personnes à mobilité réduite.



Dégager les portes au moment de leur fermeture.



Tenir une barre d'appui lorsque le train est en mouvement.



Tenir votre sac à dos à la main.



Parler à voix basse au téléphone.

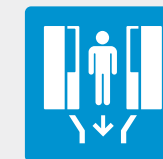

Laisser sortir les passagers d'une voiture de métro avant d'y entrer.



Lumière clignotante - Bus



Pousser la barre - Porte de bus

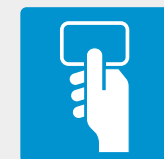

Préparer son titre

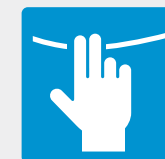

Sonner la cloche

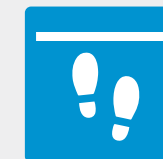

Libérer la zone du chauffeur



Se déplacer vers l'arrière



Appuyer sur le bouton lumineux



Traverser aux endroits indiqués

8 - Pictogrammes SÉCURITÉ et AVERTISSEMENTS

SÉCURITÉ



Téléphone S.O.S.



Extincteur



Extincteur



Évacuation



Frein d'urgence
AZUR



Première
MR-63



Frein d'urgence
MR-73



Feu



S.O.S.



Ouverture manuelle
de portes

AVERTISSEMENTS



Escalier roulant
Vêtements coincés



Escalier roulant
Une poussette



Escalier roulant
S'asseoir



Escalier roulant
Courir



750 volts



Courant électrique



Attention



Inflammable



Plancher glissant



Passage piétonnier



Pied coincé - Bus



Main coincée - Bus



Reculer devant un bus



Air Climatisé



Se cogner la tête

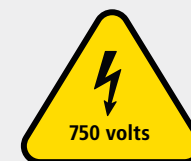

750 volts



Réparation

9 - Pictogrammes INTERDICTION



10 - Pictogrammes OBLIGATION



Passage



Fauteuil roulant



Poussette



Vélo



Déchets



Stationnement



Conserver titre valide



Bagage



Utiliser écouteurs



Ranger
objets tranchants



Rester assis / Chauffeur



Rester assis / client

11 - Flèches

TEXTE
ALIGNÉ
À GAUCHE

TEXTE
ALIGNÉ
À DROITE

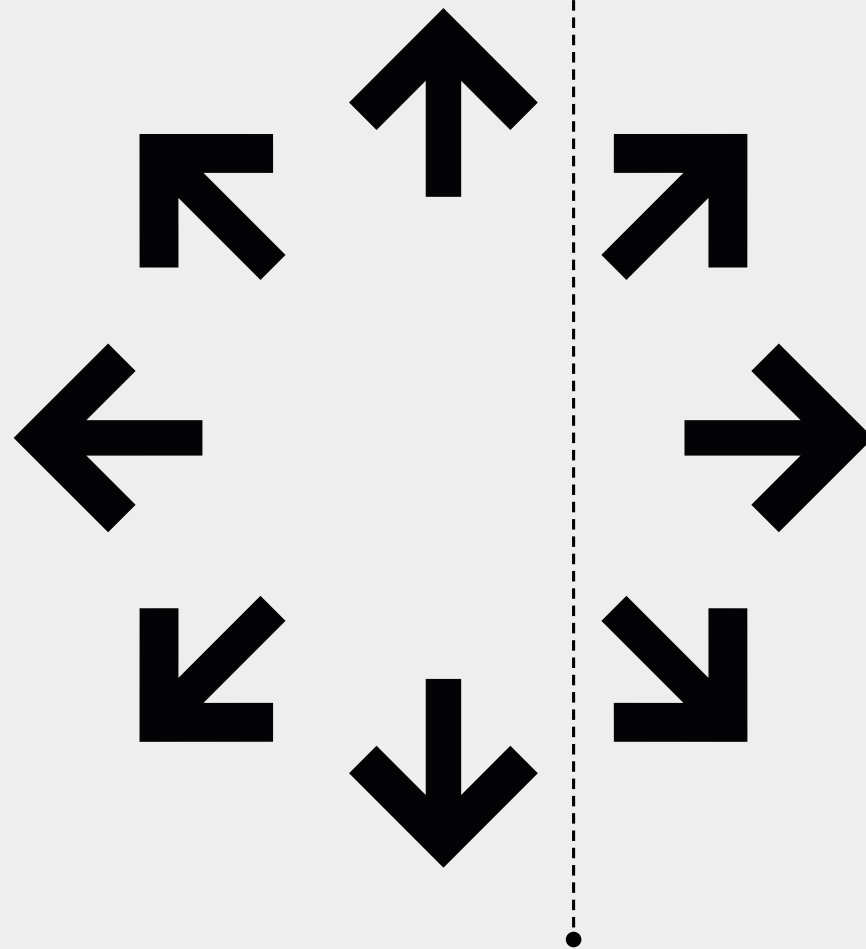

↑ ↓ Métro

Métro ↓ →



Désigne direction
droit devant / en haut



Désigne direction
gauche / droite



Désigne un déplacement
diagonal sur un même niveau
ou un changement de niveau
vers le haut



Désigne un changement de niveau
diagonal, vers le bas



Utilisé souvent pour désigner
un changement de niveau
vers le bas

12 - Identification

BANDEAU DE QUAI

● BEAUBIEN

● PARC

● JEAN-DRAPEAU

● PEEL

BANDEAU DE PORTE

● BEAUBIEN

● ● JEAN-TALON

● ● ● BERRI-UQAM

BANDEAU DE LOGE

● BEAUBIEN

● ● JEAN-TALON

● ● ● BERRI-UQAM

13 - Segmentation

SURFACE ET SERVICES

←  Ascenseur

←  24 80 97 445 747
NORD EST OUEST

Terminus Angrignon
STM • CIT • RTL  →

MÉTRO

←  Métro

←  Saint-Michel →

←   Correspondance

SORTIE

← SORTIE

← SORTIE →

← SORTIE D'URGENCE

14 - Hiérarchisation

1 - SORTIE

← SORTIE

← SORTIE D'URGENCE

2 - RUES

Rue
University **A B C** →

Chemin De La
Côte-Ste-Catherine →

3 - BUS

←  24 80 97 445 747
NORD EST OUEST

4 - AUTRES TRANSPORT

Terminus Angrignon
STM • CIT • RTL  →

5 - RIVERAINS

Place Bonaventure →

6 - ATTRAITS

↑ Plaza St-Hubert

15 - PACO

Principes



- 1 Utilisation d'un langage simplifié: minimum de mots et plus de pictogrammes
- 2 Applications des règles d'abréviations lorsque l'espace est restreint
- 3 le générique est en 2^e niveau d'information et le spécifique en 1^{er} niveau
- 4 Inscrire le générique au long (Boulevard, Avenue, Chemin, etc.)

Directionnel de surface

Destination

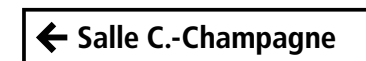
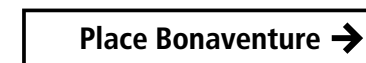

Destination (2 lignes de texte)

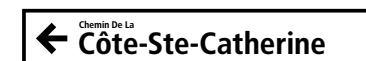

Destination (2 lignes de texte) + Lettre de sortie



Destination + Picto

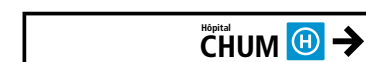
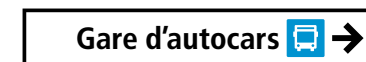

Destination + Picto (2 lignes de texte)



Bus

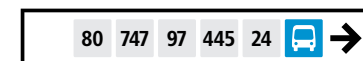
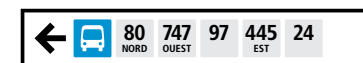

Bus (Avec indentation de navette)

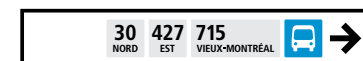

Service (1 picto)

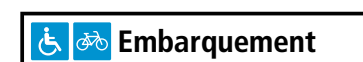
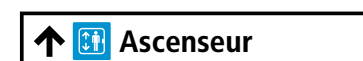
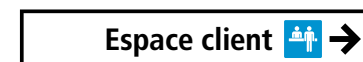

Correspondance (2^e niveau)

Seulement si un seul paco disponible pour une direction



Directionnel métro

Métro



Bout de ligne

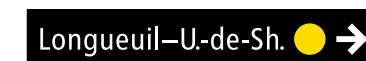
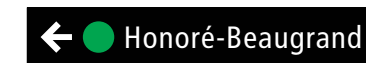

Bout de ligne (2 directions)

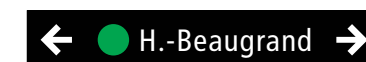

Confirmation de direction



Débarquement



Correspondance

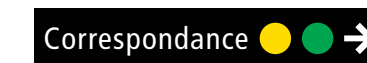

Correspondance (2^e niveau)

Seulement lorsque requis par exploitation au point de décision



Correspondance (2^e niveau) - 2 pastilles

Seulement lorsque requis par exploitation au point de décision



Correspondance (3^e niveau)

Seulement lorsque requis par exploitation au point de décision



Directionnel de sortie

Sortie



Sortie (2 directions)



Sortie + Orientation

Seulement lorsque 2 sorties ou plus sur la même rue et au 1^{er} point de décision seulement



Sortie + Lettre de sortie



Sortie d'urgence



16 - Plans

PLAN DE QUARTIER



DIRECTIONNEL PLAN DE SORTIE

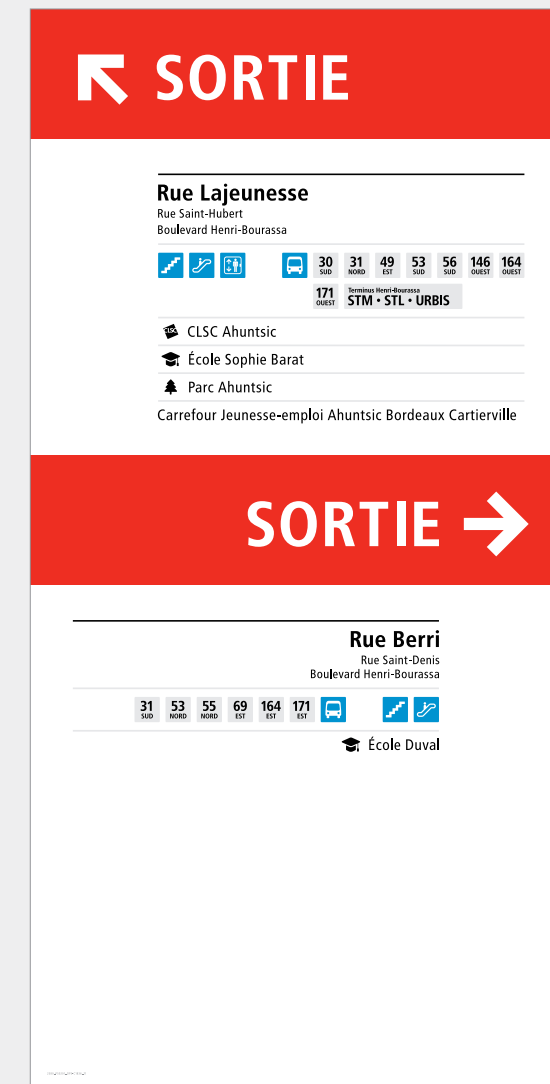

17 - Plans

PLAN DE MÉTRO



PLAN DE LIGNE



18 - Élévation

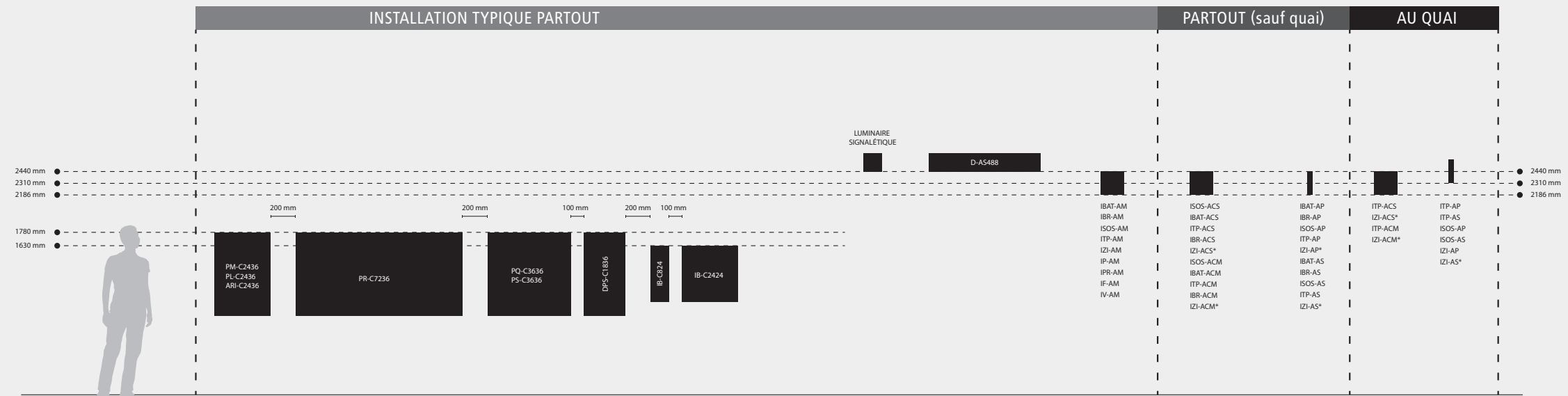

NOTES
 .1 TOUTE HAUTEUR D'INSTALLATION OU ESPACEMENT INDIQUÉ SUR PLANS ET/OU ÉLÉVATIONS SPÉCIFIQUE AU PROJET A PRIORITÉ SUR CE QUI EST INDIQUÉ SUR L'ÉLÉVATION CI-HAUT.
 .2 TOUT ÉLÉMENT OU ENSEMBLE D'ÉLÉMENTS EST CENTRÉ VERTICALEMENT SUR LE MUR/CLOISON FINI SAUF À INDICATION CONTRAIRE.
 * CENTRÉ SUR PQ OU PR LE PLUS PRÈS

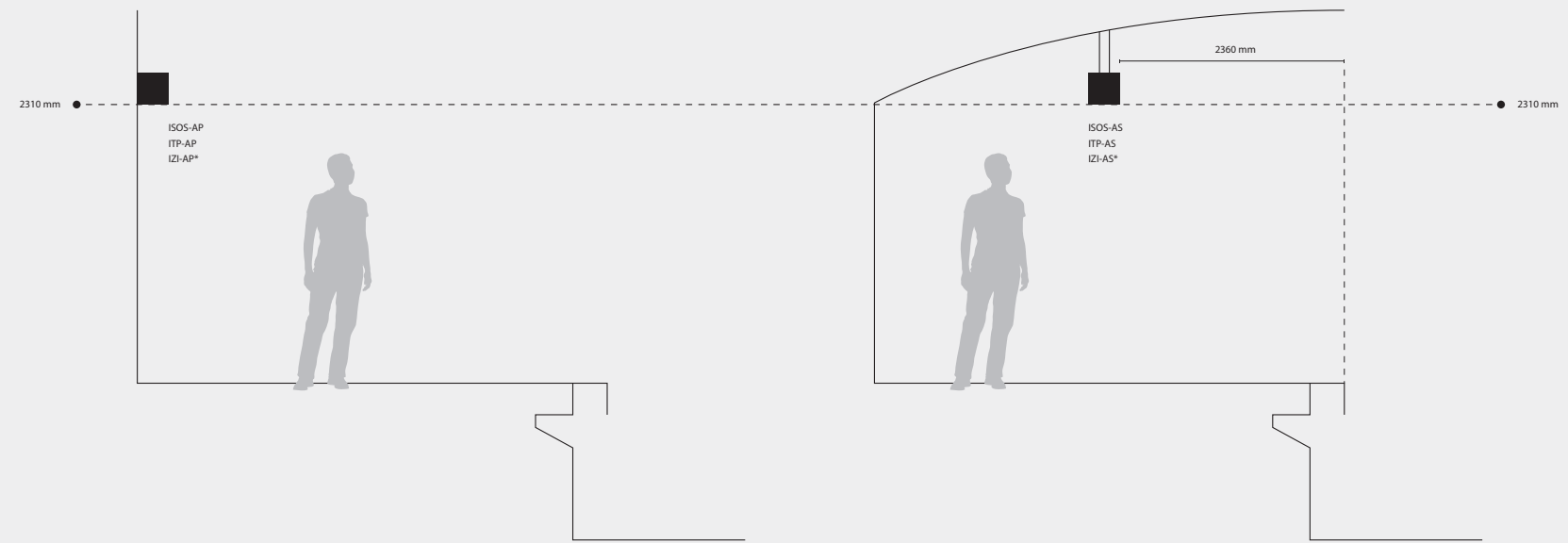

19 - Positionnement

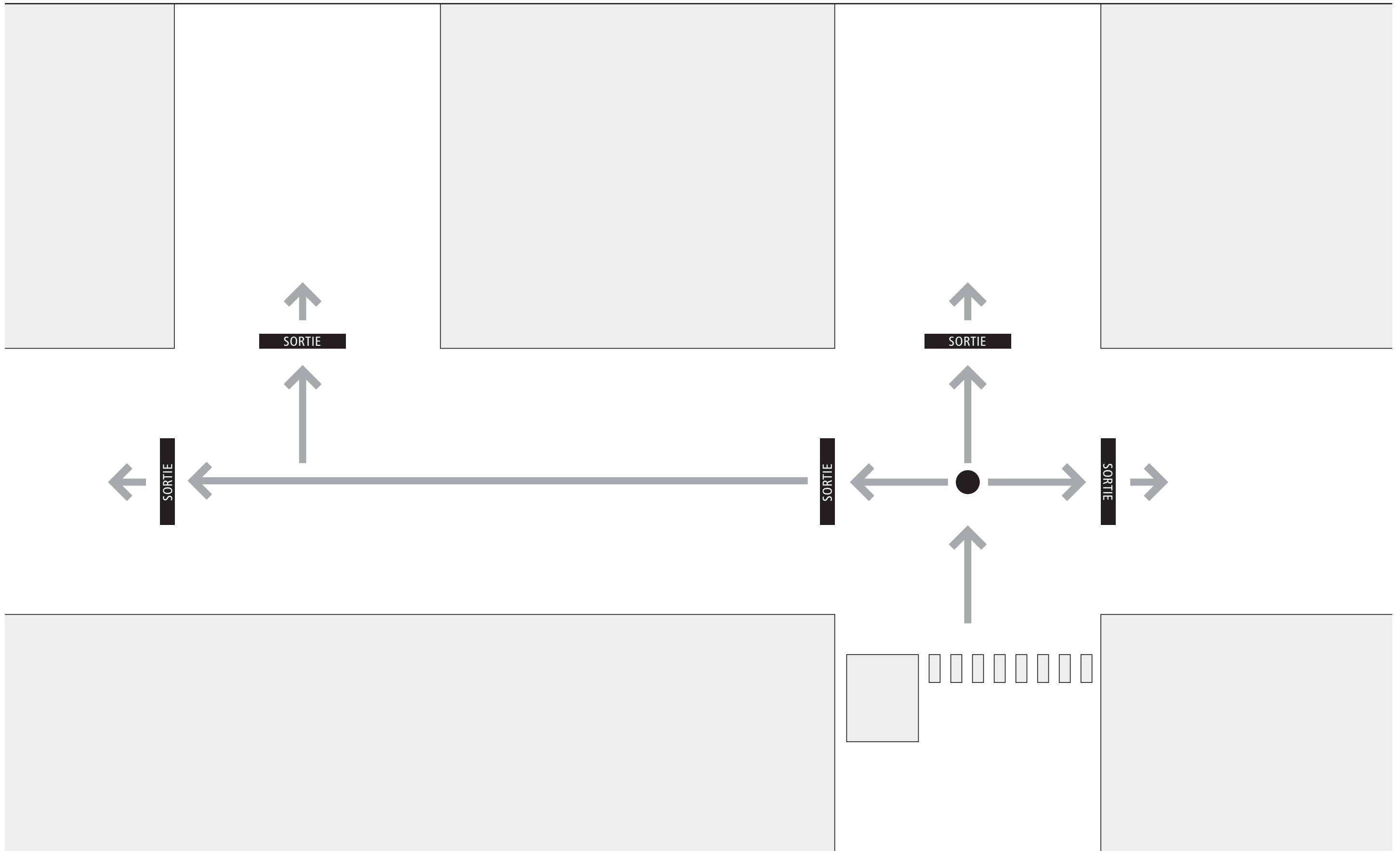

20 - Principes infos

Urgence

Standard



Zone



Zone + Titre



Avertissement

Standard



Zone

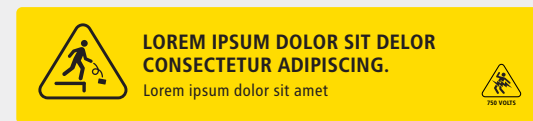

Zone + Titre

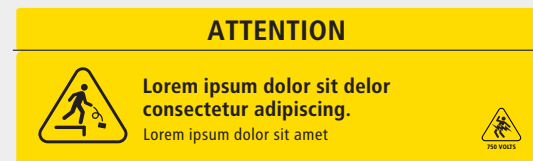

Interdiction

Standard



Zone



Zone + Titre



Obligation

Standard



Zone



Zone + Titre



21 - Principes infos

Info clientèle

Accessibilité

Standard

INSTRUCTION



Lorem ipsum dolor sit delor
consectetur adipiscing.
 Lorem ipsum dolor sit amet

Zone

 **LOREM IPSUM DOLOR SIT DELOR
CONSECTETUR ADIPISCING.**
 Lorem ipsum dolor sit amet

Zone + Titre

ZONE RÉSERVÉE



Lorem ipsum dolor sit delor
consectetur adipiscing.
 Lorem ipsum dolor sit amet

Assistance

Standard

ASSISTANCE



Lorem ipsum dolor sit delor
consectetur adipiscing.
 Lorem ipsum dolor sit amet

Zone

 **LOREM IPSUM DOLOR SIT DELOR
CONSECTETUR ADIPISCING.**
 Lorem ipsum dolor sit amet

Zone + Titre

ASSISTANCE



Lorem ipsum dolor sit delor
consectetur adipiscing.
 Lorem ipsum dolor sit amet

Information

Standard

Plans



Lorem ipsum dolor sit delor
consectetur adipiscing.
 Lorem ipsum dolor sit amet

Zone

 **LOREM IPSUM DOLOR SIT DELOR
CONSECTETUR ADIPISCING.**
 Lorem ipsum dolor sit amet